

取扱説明書 INSTRUCTIONS MANUAL

コンペティションベアリングシリーズ COMPETITION BEARING SERIES

- この取扱説明書を良く読んでからお使いください。
- 各メーカーの発行する整備要領書と併せてお使いください。
- 取り付け後も大切に保管してください。
- 販売店様で取り付けをされる場合は本書を必ずお客様へお渡しください。

TOMEI 製品のお買い上げありがとうございます。

エンジンチューニングによる燃焼圧力の増大や高回転化は、使用するベアリングに対し耐焼付性、耐疲労性、耐摩耗性などの軸受性能が求められます。

コンペティションベアリングシリーズは、よりハードな使用目的に対応すべく、軸受材にエンジンベアリングに必要とされる様々な軸受性能をバランスさせたバイメタルを採用。高い順応性と負荷能力を確保します。



当製品は様々な自動車メーカーのエンジンベアリングおよびエンジン部品を手がけている、オーストラリアのACL Bearing Companyとの提携製品です。

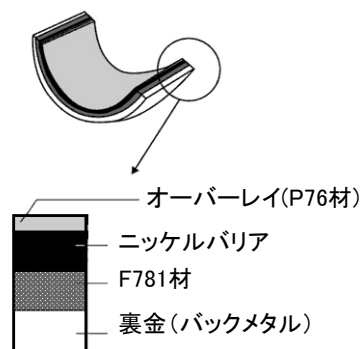

- Installation of the production is to be carried out after the instructions are carefully read.
- Please use this instruction manual in conjunction with the workshop manual published specifically for your car.
- Be sure to give a copy of this instruction manual to the customer.

Thank you for purchasing another quality TOMEI product.

When used in high RPM conditions with higher loads and combustion pressures in high end tuned engines the bearings efficiency is then greatly changed. Bearings are not always designed for high end engines so their fatigue & abrasion resistance is much lower than what is required from big power producing engines.

Our competition bearing series are specifically designed and tested for high end competition use on big power applications and for extended life durability. With the combined balanced use of these metals we can design the required bearings to suit the applications that our end users are used to and require.



This product has been made by an Australian Company ACL whom makes OEM bearings for other car manufacturers. This joint venture allowed us to make these competition bearings to our specifications.

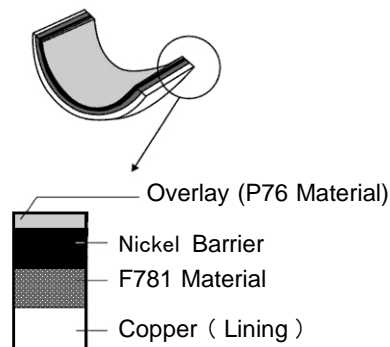

注意

- 本品は自動車競技専用部品です。サーキットや公道から閉鎖されたコース内に限って使用してください。
- 本品の取り付けは特別の訓練を受けた整備士が、設備の整った作業場で実施してください。
- 指定する車種以外への取り付けはおやめください。本品およびエンジンを破損する恐れがあります。
- 本品は使用するコンロッドやクランクに指定されたオイルクリアランスの基準値になるよう、必ず測定し算出した物を選択してください。
- 一般的にエンジンベアリングの最終工程で表面処理(グレイorシルバーの色)が施されていますが、当製品ではそれら表面処理はベアリング本来の品質を追求した上では不要とし、実施していません。その為、表面の色に斑が発生していますが製品上一切問題はなく、製品の不良でない事をご了承ください。
- また上記の理由により、出荷時ではオイルコーティングを施しておりますので製品使用時には必ず洗浄および脱脂を行ってください。
- 保存の際はオイルコーティングを剥がさずに保存し、ご購入から3年以内に使用してください。

ベアリング対応表

| メーカー | エンジン | 車種 | 位置 | | 品番 | グレード | サイズ | 識別色 | 参考純正 グレード | | |
|------------|------------------------|------------------------|---------|------------------------------------|-------------|-------------|-------------|-------------|--------------|---|---|
| NISSAN | RB26DETT RB25DE (T) | R32 R33 R34 | メインインナー | アッパー | 1231N1101A | A | 1.818~1.821 | 黒 | 0 | | |
| | | | | | 1231N1101B | B | 1.821~1.824 | 緑 | 1 | | |
| | | | | | 1231N1101C | C | 1.824~1.827 | 黄色 | 2 | | |
| | | | | | 1231N1101D | D | 1.827~1.830 | 赤 | 3 | | |
| | | | | ロア | 1231N1201A | A | 1.818~1.821 | 黒 | 0 | | |
| | | | | | 1231N1201B | B | 1.821~1.824 | 緑 | 1 | | |
| | | | | | 1231N1201C | C | 1.824~1.827 | 黄色 | 2 | | |
| | | | | | 1231N1201D | D | 1.827~1.830 | 赤 | 3 | | |
| | | | メインセンター | アッパー | 1231N2101A | A | 1.818~1.821 | 黒 | 0 | | |
| | | | | | 1231N2101B | B | 1.821~1.824 | 緑 | 1 | | |
| | | | | | 1231N2101C | C | 1.824~1.827 | 黄色 | 2 | | |
| | | | | | 1231N2101D | D | 1.827~1.830 | 赤 | 3 | | |
| | ロア | 1231N2201A | | A | 1.818~1.821 | 黒 | 0 | | | | |
| | | 1231N2201B | | B | 1.821~1.824 | 緑 | 1 | | | | |
| | | 1231N2201C | | C | 1.824~1.827 | 黄色 | 2 | | | | |
| | | 1231N2201D | | D | 1.827~1.830 | 赤 | 3 | | | | |
| | コンロッド | 1232N0001A | A | 1.500~1.503 | 黒 | 0 | | | | | |
| | | 1232N0001B | B | 1.503~1.506 | 緑 | 1 | | | | | |
| | | 1232N0001C | C | 1.506~1.509 | 黄色 | 2 | | | | | |
| | SR20DE (T) | (R) PS13 S14 S15 | メイン | アッパー | 1231N1102A | A | 1.977~1.980 | 黒 | 0 | | |
| | | | | | 1231N1102B | B | 1.980~1.983 | 緑 | 1 | | |
| | | | | | 1231N1102C | C | 1.983~1.986 | 黄色 | 2 | | |
| | | | | ロア | 1231N1202A | A | 1.977~1.980 | 黒 | 0 | | |
| | | | | | 1231N1202B | B | 1.980~1.983 | 緑 | 1 | | |
| | | | | | 1231N1202C | C | 1.983~1.986 | 黄色 | 2 | | |
| | | | コンロッド | 1232N0001A | A | 1.500~1.503 | 黒 | 0 | | | |
| | | | | 1232N0001B | B | 1.503~1.506 | 緑 | 1 | | | |
| | | | | 1232N0001C | C | 1.506~1.509 | 黄色 | 2 | | | |
| | | | VQ35DE | Z33 V35 ※Z33 HRは 使用不可 | メイン | アッパー | 1231N1103A | A | 2.003~2.006 | 黒 | 1 |
| | | | | | | | 1231N1103B | B | 2.006~2.009 | 緑 | 2 |
| 1231N1103C | | | | | | | C | 2.009~2.012 | 黄色 | 3 | |
| ロア | 1231N1203A | A | | | | 2.003~2.006 | 黒 | 1 | | | |
| | 1231N1203B | B | | | | 2.006~2.009 | 緑 | 2 | | | |
| | 1231N1203C | C | | | | 2.009~2.012 | 黄色 | 3 | | | |
| コンロッド | 1232N0002A | A | | | 1.503~1.506 | 黒 | 1 | | | | |
| | 1232N0002B | B | | | 1.506~1.509 | 緑 | 2 | | | | |
| | 1232N0002C | C | | | 1.509~1.512 | 黄色 | - | | | | |

| メーカー | エンジン | 車種 | 位置 | | 品番 | グレード | サイズ | 識別色 | 参考純正 グレード | |
|------------|----------------|--|------------|------------|-------------|-------------|-------------|-------------|--------------|---|
| TOYOTA | 1JZ 2JZ | JZA70 JZA80 JZX90 JZX100 JZX110 JZZ30 JZS171 | メイン1 | アッパー | 1231T1101A | A | 1.992~1.996 | 黒 | 1 | |
| | | | | | 1231T1101B | B | 1.996~2.000 | 緑 | 2 | |
| | | | | | 1231T1101C | C | 2.000~2.004 | 黄色 | 3 | |
| | | | | ロア | 1231T1201A | A | 1.992~1.996 | 黒 | 1 | |
| | | | | | 1231T1201B | B | 1.996~2.000 | 緑 | 2 | |
| | | | | | 1231T1201C | C | 2.000~2.004 | 黄色 | 3 | |
| | | | JZS161※注 | メイン2~7 | アッパー | 1231T1102A | A | 1.992~1.996 | 黒 | 1 |
| | | | | | | 1231T1102B | B | 1.996~2.000 | 緑 | 2 |
| | | | | | | 1231T1102C | C | 2.000~2.004 | 黄色 | 3 |
| | | ロア | | 1231T1202A | A | 1.992~1.996 | 黒 | 1 | | |
| | | | | 1231T1202B | B | 1.996~2.000 | 緑 | 2 | | |
| | | | | 1231T1202C | C | 2.000~2.004 | 黄色 | 3 | | |
| | | コンロッド | 1232T0001A | A | 1.490~1.494 | 黒 | 2 | | | |
| | | | 1232T0001B | B | 1.494~1.498 | 緑 | 3 | | | |
| | | | 1232T0001C | C | 1.498~1.502 | 黄色 | 4 | | | |
| MITSUBISHI | 4G63 Evo5~ | CP9A CT9A | メイン | アッパー | 1231M1101A | A | 1.985~1.988 | 黒 | - | |
| | | | | | 1231M1101B | B | 1.988~1.991 | 緑 | - | |
| | | | | | 1231M1101C | C | 1.991~1.994 | 黄色 | - | |
| | | | | ロア | 1231M1201A | A | 1.985~1.988 | 黒 | - | |
| | | | | | 1231M1201B | B | 1.988~1.991 | 緑 | - | |
| | | | | | 1231M1201C | C | 1.991~1.994 | 黄色 | - | |
| | | | コンロッド | 1232M0001A | A | 1.485~1.488 | 黒 | - | | |
| | | | | 1232M0001B | B | 1.488~1.491 | 緑 | - | | |
| | | | | 1232M0001C | C | 1.491~1.494 | 黄色 | - | | |
| SUBARU | EJ205 EJ207 | GDA GDB | メイン 1&3 | 1231S1001A | A | 1.998~2.001 | 黒 | - | | |
| | | | | 1231S1001B | B | 2.001~2.004 | 緑 | - | | |
| | | | | 1231S1001C | C | 2.004~2.007 | 黄色 | - | | |
| | | | メイン 2&4 | 1231S1002A | A | 1.998~2.001 | 黒 | - | | |
| | | | | 1231S1002B | B | 2.001~2.004 | 緑 | - | | |
| | | | | 1231S1002C | C | 2.004~2.007 | 黄色 | - | | |
| | | | メイン 5 | 1231S2001A | A | 1.998~2.001 | 黒 | - | | |
| | | | | 1231S2001B | B | 2.001~2.004 | 緑 | - | | |
| | | | | 1231S2001C | C | 2.004~2.007 | 黄色 | - | | |
| | | | コンロッド | 1232S0001A | A | 1.485~1.488 | 黒 | - | | |
| | | | | 1232S0001B | B | 1.488~1.491 | 緑 | - | | |
| | | | | 1232S0001C | C | 1.491~1.494 | 黄色 | - | | |

※注:JZS161には次の年式の車両のみ使用できます。メインメタル(1997.8~2001.8) コンロッドメタル(1997.8~2001.6)

CAUTION

- This product is only for vehicle use under a closed circuit and for public roads.
- The technician for this installation must be a licensed mechanic, which holds a thorough understanding for installations.
- Only install this product on the specific model as stated above.
If installed on a different model, possible engine damage will occur.
- This product requires the oil clearance to be calculated between the crank and conrod prior to use.
- Our bearings may show signs of uneven color or color blemishes but please do not be alarmed as these are designed as true race use bearings.
Usually when bearings are manufactured for standard use engines there is an additional process done for a gray or silver finish but this process has not additional merits for.
- There is a layer of special oil on the bearings to protect the bearings from rust and scratches during shipping and storage. Please thoroughly remove this protective coating prior to installation.
- If the bearings are not going to be used immediately then do not remove the protective coating.
This will allow the bearings to be stored for up to 3 years.

BEARING CHART LIST

| Maker | Engine | Car Model | Position | | Part No. | Grade | Size | ID Color | OEM Grade Reference |
|------------|------------|--------------------------|-------------|-------------|---|-------------|-------------|------------|---------------------|
| NISSAN | RB26DETT | BNR32 BCNR33 BNR34 | Main Inner | Upper | 1231N1101A | A | 1.818~1.821 | Black | 0 |
| | | | | | 1231N1101B | B | 1.821~1.824 | Green | 1 |
| | | | | | 1231N1101C | C | 1.824~1.827 | Yellow | 2 |
| | | | | | 1231N1101D | D | 1.827~1.830 | Red | 3 |
| | | | | Lower | 1231N1201A | A | 1.818~1.821 | Black | 0 |
| | | | | | 1231N1201B | B | 1.821~1.824 | Green | 1 |
| | | | | | 1231N1201C | C | 1.824~1.827 | Yellow | 2 |
| | | | | | 1231N1201D | D | 1.827~1.830 | Red | 3 |
| | | | Main Center | Upper | 1231N2101A | A | 1.818~1.821 | Black | 0 |
| | | | | | 1231N2101B | B | 1.821~1.824 | Green | 1 |
| | | | | | 1231N2101C | C | 1.824~1.827 | Yellow | 2 |
| | | | | | 1231N2101D | D | 1.827~1.830 | Red | 3 |
| | | | | Lower | 1231N2201A | A | 1.818~1.821 | Black | 0 |
| | | | | | 1231N2201B | B | 1.821~1.824 | Green | 1 |
| | | | | | 1231N2201C | C | 1.824~1.827 | Yellow | 2 |
| | | | | | 1231N2201D | D | 1.827~1.830 | Red | 3 |
| | Conrod | 1232N0001A | A | 1.500~1.503 | Black | 0 | | | |
| | | 1232N0001B | B | 1.503~1.506 | Green | 1 | | | |
| | | 1232N0001C | C | 1.506~1.509 | Yellow | 2 | | | |
| | SR20DE (T) | (R) PS13 S14 S15 | Main | Upper | 1231N1102A | A | 1.977~1.980 | Black | 0 |
| | | | | | 1231N1102B | B | 1.980~1.983 | Green | 1 |
| | | | | | 1231N1102C | C | 1.983~1.986 | Yellow | 2 |
| | | | | Lower | 1231N1202A | A | 1.977~1.980 | Black | 0 |
| | | | | | 1231N1202B | B | 1.980~1.983 | Green | 1 |
| | | | | | 1231N1202C | C | 1.983~1.986 | Yellow | 2 |
| | | | Conrod | 1232N0001A | A | 1.500~1.503 | Black | 0 | |
| | | | | 1232N0001B | B | 1.503~1.506 | Green | 1 | |
| | | | | 1232N0001C | C | 1.506~1.509 | Yellow | 2 | |
| | | | | VQ35DE | Z33 V35 ※Cannot use Z33 HR | Main | Upper | 1231N1103A | A |
| | 1231N1103B | B | 2.006~2.009 | | | | | Green | 2 |
| | 1231N1103C | C | 2.009~2.012 | | | | | Yellow | 3 |
| | Lower | 1231N1203A | A | | | | 2.003~2.006 | Black | 1 |
| | | 1231N1203B | B | | | | 2.006~2.009 | Green | 2 |
| | | 1231N1203C | C | | | | 2.009~2.012 | Yellow | 3 |
| | Conrod | 1232N0002A | A | | | 1.503~1.506 | Black | 1 | |
| | | 1232N0002B | B | | | 1.506~1.509 | Green | 2 | |
| 1232N0002C | | C | 1.509~1.512 | | | Yellow | - | | |

※Designed to be used with JZS161 models only. Main bearing(1997.8~2001.8),Conrod bearing(1997.8~2001.6).

| Maker | Engine | Car Model | Position | | Part No. | Grade | Size | ID Colour | OEM Grade Reference |
|------------|----------------------------------|---|----------|------------|------------|-------------|-------------|-----------|---------------------|
| TOYOTA | 1JZ 2JZ | JZA70 JZA80 JZX90 JZX100 JZX110 JZZ30 JZS171 JZS161※ | Main 1 | Upper | 1231T1101A | A | 1.992~1.996 | Black | 1 |
| | | | | | 1231T1101B | B | 1.996~2.000 | Green | 2 |
| | | | | | 1231T1101C | C | 2.000~2.004 | Yellow | 3 |
| | | | | Lower | 1231T1201A | A | 1.992~1.996 | Black | 1 |
| | | | | | 1231T1201B | B | 1.996~2.000 | Green | 2 |
| | | | | | 1231T1201C | C | 2.000~2.004 | Yellow | 3 |
| | | | Main 2~7 | Upper | 1231T1102A | A | 1.992~1.996 | Black | 1 |
| | | | | | 1231T1102B | B | 1.996~2.000 | Green | 2 |
| | | | | | 1231T1102C | C | 2.000~2.004 | Yellow | 3 |
| | | | | Lower | 1231T1202A | A | 1.992~1.996 | Black | 1 |
| | | | | | 1231T1202B | B | 1.996~2.000 | Green | 2 |
| | | | | | 1231T1202C | C | 2.000~2.004 | Yellow | 3 |
| | | | Conrod | 1232T0001A | A | 1.490~1.494 | Black | 2 | |
| | | | | 1232T0001B | B | 1.494~1.498 | Green | 3 | |
| | | | | 1232T0001C | C | 1.498~1.502 | Yellow | 4 | |
| MITSUBISHI | 4G63 Evo5~ | CP9A CT9A | Main | Upper | 1231M1101A | A | 1.985~1.988 | Black | - |
| | | | | | 1231M1101B | B | 1.988~1.991 | Green | - |
| | | | | | 1231M1101C | C | 1.991~1.994 | Yellow | - |
| | | | | Lower | 1231M1201A | A | 1.985~1.988 | Black | - |
| | | | | | 1231M1201B | B | 1.988~1.991 | Green | - |
| | | | | | 1231M1201C | C | 1.991~1.994 | Yellow | - |
| | | | Conrod | 1232M0001A | A | 1.488~1.491 | Black | - | |
| | | | | 1232M0001B | B | 1.491~1.494 | Green | - | |
| | | | | 1232M0001C | C | 1.494~1.497 | Yellow | - | |
| | | | | | | | | | |
| SUBARU | EJ205 EJ207 EJ255 EJ257 | GDA GDB | Main 1&3 | 1231S1001A | A | 1.998~2.001 | Black | - | |
| | | | | 1231S1001B | B | 2.001~2.004 | Green | - | |
| | | | | 1231S1001C | C | 2.004~2.007 | Yellow | - | |
| | | | Main 2&4 | 1231S1002A | A | 1.998~2.001 | Black | - | |
| | | | | 1231S1002B | B | 2.001~2.004 | Green | - | |
| | | | | 1231S1002C | C | 2.004~2.007 | Yellow | - | |
| | | | Main 5 | 1231S2001A | A | 1.998~2.001 | Black | - | |
| | | | | 1231S2001B | B | 2.001~2.004 | Green | - | |
| | | | | 1231S2001C | C | 2.004~2.007 | Yellow | - | |
| | | | Conrod | 1232S0001A | A | 1.485~1.488 | Black | - | |
| | | | | 1232S0001B | B | 1.488~1.491 | Green | - | |
| | | | | 1232S0001C | C | 1.491~1.494 | Yellow | - | |

●この製品に関わる取り付け、操作上のご相談は上記へお願いします。

営業部 042-795-8411

営業時間：月～金（祝祭日、年末年始を除く）9：00～18：00

If you have any questions in regards to the installation of this product,
please contact your local authorised Tomei Powered distributor.

OPEN: Monday - Friday (National holidays and public holidays excluded). 09:00 - 18:00

TOMEI POWERED INC.
株式会社 東名パワード

〒194-0004 東京都町田市鶴間1737-3

TEL 042-795-8411(代)

FAX 042-799-7851

<http://www.tomei-p.co.jp>

1737-3 Tsuruma Machida-shi Tokyo 194-0004,JAPAN
Tel: +81-42-795-8411(main switchboard) /Fax: +81-42-799-7851

コンペティションベアリングシリーズ取扱説明書 08年4月 M12K440